

### Silicon Planar Zener Diodes

#### Features

- Total power dissipation: Max. 200 mW
- Small plastic package suitable for surface mounted design
- Tolerance approximately  $\pm 5\%$
- AEC-Q101 Qualified and PPAP Capable.

#### PINNING

PIN	DESCRIPTION
1	Cathode
2	Anode

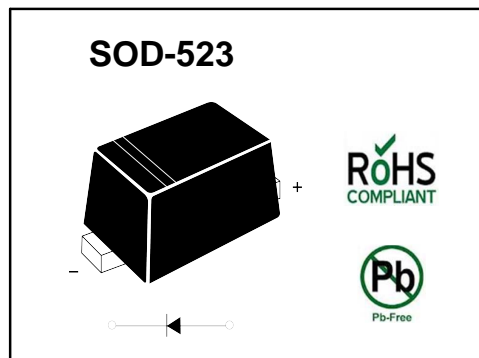

#### Absolute Maximum Ratings ( $T_a = 25\text{ }^\circ\text{C}$ )

Parameter	Symbol	Value	Unit
Power Dissipation	$P_{tot}$	200	mW
Junction Temperature	$T_j$	150	$^\circ\text{C}$
Storage Temperature Range	$T_{stg}$	- 55 to + 150	$^\circ\text{C}$

#### Characteristics at $T_a = 25\text{ }^\circ\text{C}$

Parameter	Symbol	Max.	Unit
Thermal Resistance Junction to Ambient Air	$R_{\theta JA}$	417	$^\circ\text{C}/\text{W}$
Forward Voltage at $I_F = 10\text{ mA}$	$V_F$	0.9	V

## Characteristics at $T_a = 25\text{ }^\circ\text{C}$

Type	Marking Code	Zener Voltage Range <sup>1)</sup>			Dynamic Impedance			Reverse Current	
		$V_{znom}$ V	$I_{zT}$ for $V_{zT}$		$Z_{zT}$ $\Omega$ (Max.)	$Z_{zK}$ $\Omega$ (Max.)	at $I_{zK}$ mA	$I_R$ $\mu\text{A}$ (Max.)	at $V_R$ V
			mA	V					
MM5Z5221B	A1	2.4	20	2.28...2.52	30	1200	0.25	100	1
MM5Z5223B	B1	2.7	20	2.57...2.84	30	1300	0.25	75	1
MM5Z5225B	C1	3.0	20	2.85...3.15	29	1600	0.25	50	1
MM5Z5226B	D1	3.3	20	3.14...3.47	28	1600	0.25	25	1
MM5Z5227B	E1	3.6	20	3.42...3.78	24	1700	0.25	15	1
MM5Z5228B	F1	3.9	20	3.71...4.1	23	1900	0.25	10	1
MM5Z5229B	H1	4.3	20	4.09...4.52	22	2000	0.25	5	1
MM5Z5230B	J1	4.7	20	4.47...4.94	19	1900	0.25	5	2
MM5Z5231B	K1	5.1	20	4.85...5.36	17	1600	0.25	5	2
MM5Z5232B	M1	5.6	20	5.32...5.88	11	1600	0.25	5	3
MM5Z5234B	N1	6.2	20	5.89...6.51	7	1000	0.25	5	4
MM5Z5235B	P1	6.8	20	6.46...7.14	5	750	0.25	3	5
MM5Z5236B	R1	7.5	20	7.13...7.88	6	500	0.25	3	6
MM5Z5237B	X1	8.2	20	7.79...8.61	8	500	0.25	3	6.5
MM5Z5239B	Y1	9.1	20	8.65...9.56	10	600	0.25	3	7
MM5Z5240B	Z1	10	20	9.5...10.5	17	600	0.25	3	8
MM5Z5241B	A2	11	20	10.45...11.55	22	600	0.25	2	8.4
MM5Z5242B	B2	12	20	11.4...12.6	30	600	0.25	1	9.1
MM5Z5243B	C2	13	9.5	12.35...13.65	13	600	0.25	0.5	9.9
MM5Z5245B	D2	15	8.5	14.25...15.75	16	600	0.25	0.1	11
MM5Z5246B	E2	16	7.8	15.2...16.8	17	600	0.25	0.1	12
MM5Z5248B	F2	18	7	17.1...18.9	21	600	0.25	0.1	14
MM5Z5249B	N9	19	6.6	18.05...19.95	23	600	0.25	0.1	14
MM5Z5250B	H2	20	6.2	19...21	25	600	0.25	0.1	15
MM5Z5251B	J2	22	5.6	20.9...23.1	29	600	0.25	0.1	17
MM5Z5252B	K2	24	5.2	22.8...25.2	33	600	0.25	0.1	18
MM5Z5253B	P9	25	5	23.75...26.25	35	600	0.25	0.1	19
MM5Z5254B	M2	27	4.6	25.65...28.35	41	600	0.25	0.1	21
MM5Z5256B	N2	30	4.2	28.5...31.5	49	600	0.25	0.1	23
MM5Z5257B	P2	33	3.8	31.35...34.65	58	700	0.25	0.1	25
MM5Z5258B	R2	36	3.4	34.2...37.8	70	700	0.25	0.1	27
MM5Z5259B	X2	39	3.2	37.05...40.95	80	800	0.25	0.1	30
MM5Z5260B	Y2	43	3	40.85...45.15	93	900	0.25	0.1	33
MM5Z5261B	Z2	47	2.7	44.65...49.35	105	1000	0.25	0.1	36
MM5Z5262B	A3	51	2.5	48.45...53.55	125	1100	0.25	0.1	39
MM5Z5263B	B3	56	2.2	53.2...58.8	150	1300	0.25	0.1	43
MM5Z5265B	C3	62	2	58.9...65.1	185	1400	0.25	0.1	47
MM5Z5266B	D3	68	1.8	64.6...71.4	230	1600	0.25	0.1	52
MM5Z5267B	E3	75	1.7	71.25...78.75	270	1700	0.25	0.1	56

<sup>1)</sup>  $V_z$  is tested with pulses (20 ms)

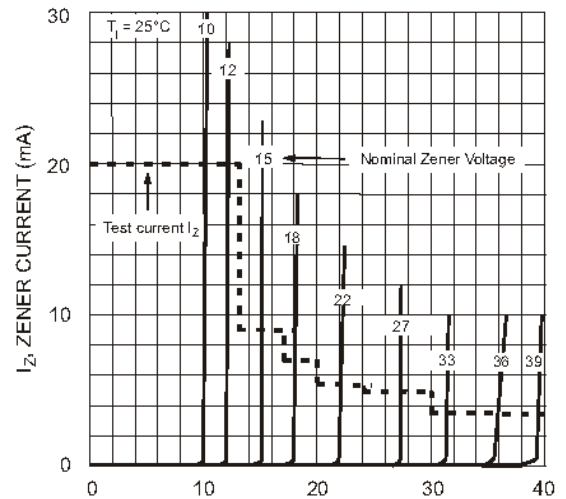
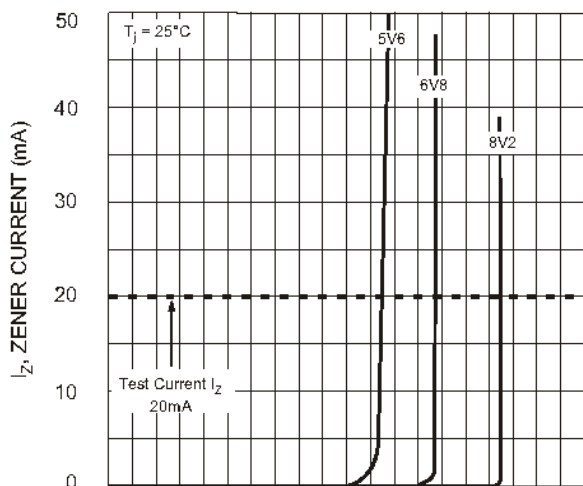
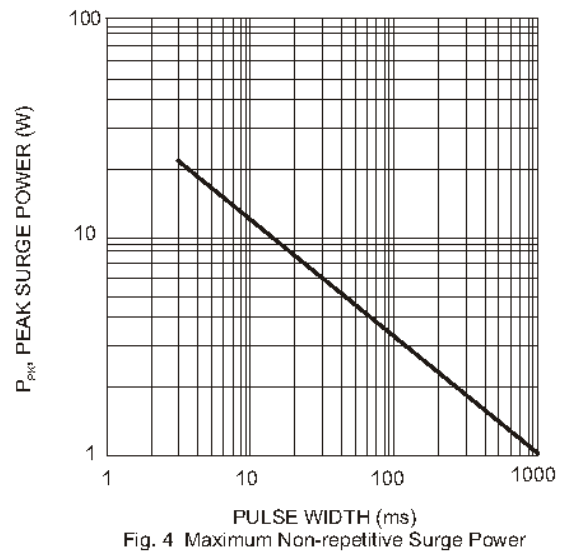
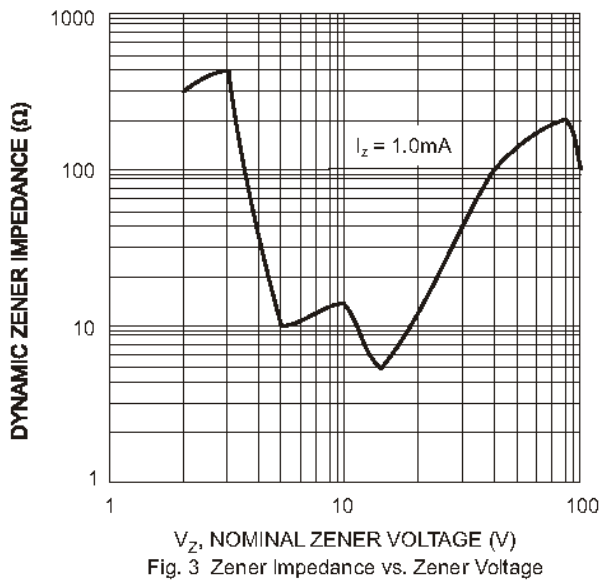
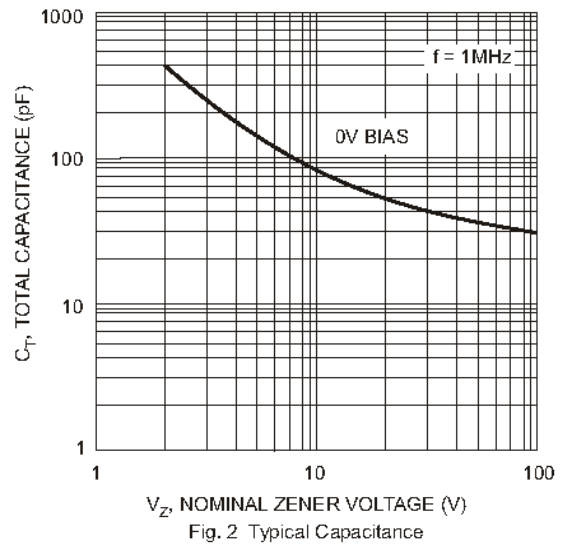
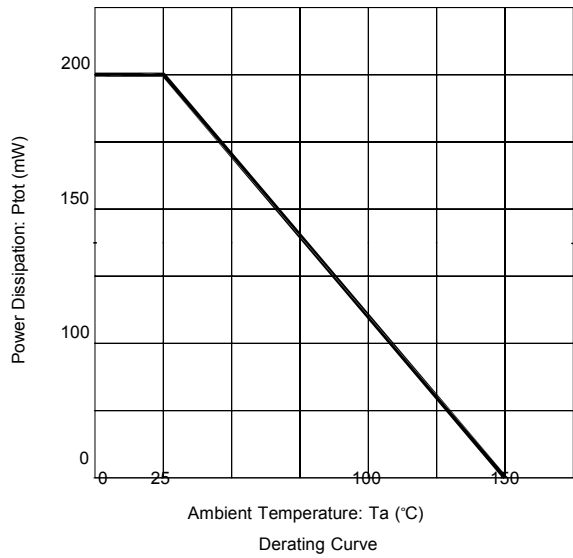

### SOD-523 Embossed Carrier Tape

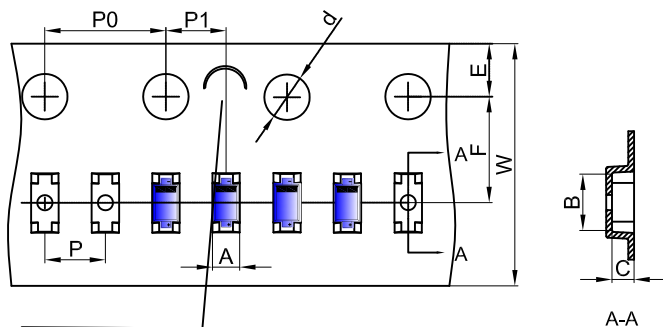

NOTE: TO GAVE 'C' ON CARRIER TAPE PER 120MM

Dimensions are in millimeter										
Pkg type	A	B	C	d	E	F	P0	P	P1	W
SOD-523	0.9	1.94	0.73	Ø1.50	1.75	3.50	4.00	2.00	2.00	8.00

### SOD-523 Tape Leader and Trailer

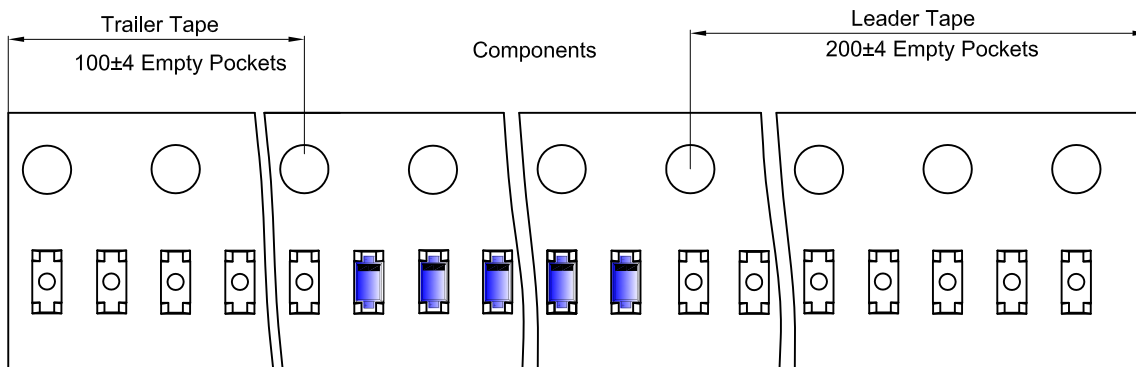

### SOD-523 Reel

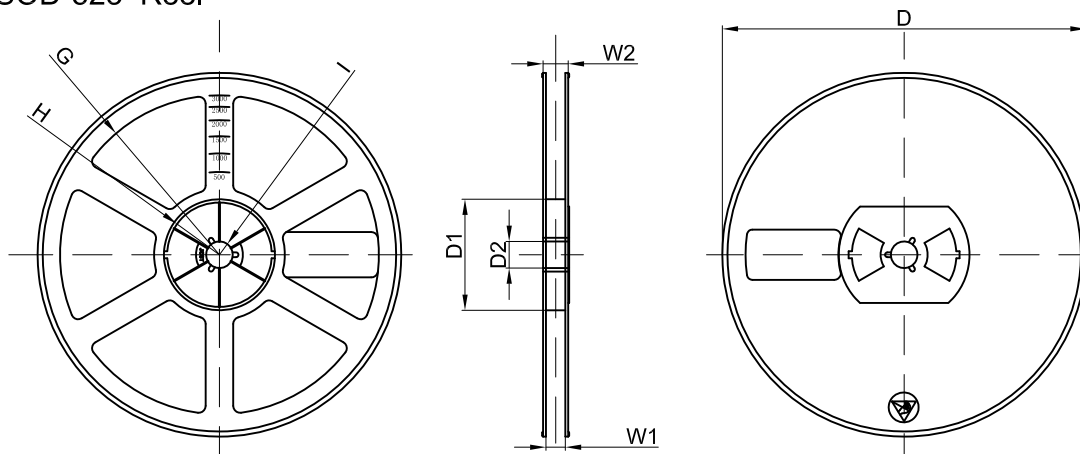

Dimensions are in millimeter								
Reel Option	D	D1	D2	G	H	I	W1	W2
7" Dia	Ø178.00	54.40	13.00	R78.00	R25.60	R6.50	9.50	12.30

REEL	Reel Size	Box	Box Size(mm)	Carton	Carton Size(mm)	G.W.(kg)
8000 pcs	7 inch	120,000 pcs	203×203×195	480,000 pcs	438×438×220	

### SOD-523 Package Outline Dimensions

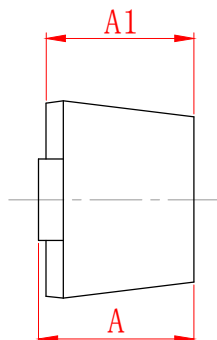
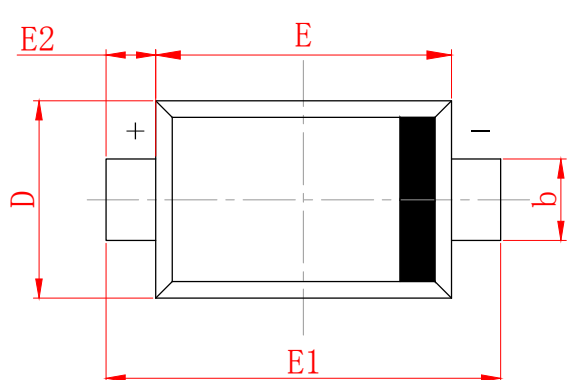

SYMBOL	MILLIMETER	
	MIN	MAX
A	0.530	0.730
A1	0.500	0.700
b	0.280	0.380
c	0.080	0.150
D	0.750	0.850
E	1.100	1.300
E1	1.500	1.700
E2	0.200 REF	
L	0.010	0.070
$\theta$	7° REF	

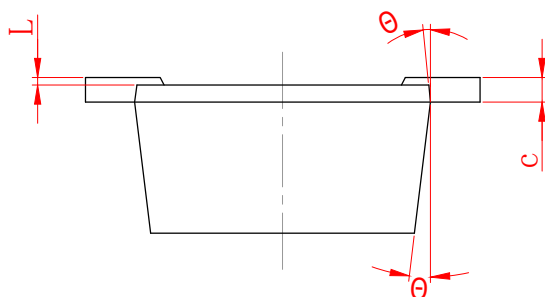

### DISCLAIMER

JHG PROVIDES TECHNICAL AND RELIABILITY DATA (INCLUDING DATASHEETS), DESIGN RESOURCES (INCLUDING REFERENCE DESIGNS), APPLICATION OR OTHER DESIGN ADVICE, SAFETY INFORMATION, AND OTHER RESOURCES "AS IS" AND WITH ALL FAULTS, AND DISCLAIMS ALL WARRANTIES, EXPRESS AND IMPLIED, INCLUDING WITHOUT LIMITATION ANY IMPLIED WARRANTIES OF MERCHANTABILITY, FITNESS FOR A PARTICULAR PURPOSE OR NON-INFRINGEMENT OF THIRD PARTY INTELLECTUAL PROPERTY RIGHTS.

These resources are intended for skilled developers designing with JHG products. You are solely responsible for

- (1) selecting the appropriate JHG products for your application;
- (2) designing, validating and testing your application;
- (3) ensuring your application meets applicable standards, and any other safety, security, or other requirements.

These resources are subject to change without notice. JHG grants you permission to use these resources only for development of an application that uses the JHG products described in the resource. Other reproduction and display of these resources are prohibited. No license is granted to any other JHG intellectual property right or to any third party intellectual property right. JHG disclaims responsibility for, and you will fully indemnify JHG and its representatives against, any claims, damages, costs, losses, and liabilities arising out of your use of these resources.