

### SOD-523 Plastic-Encapsulate Diode

#### PINNING

PIN	DESCRIPTION
1	Cathode
2	Anode

#### ZENER DIODE

#### FEATURES

- Planar Die Construction
- 150mW Power Dissipation
- Zener Voltages from 2.4 – 39V

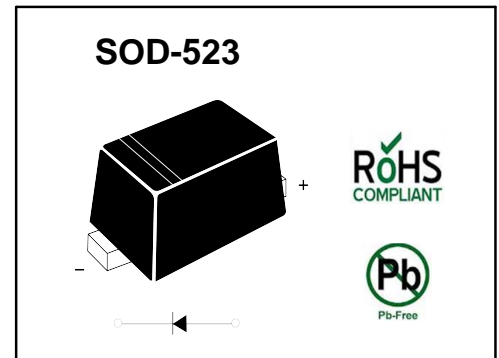

#### MAXIMUM RATINGS( $T_a=25^{\circ}\text{C}$ unless otherwise specified )

Characteristic	Symbol	Value	Unit
Forward Voltage @ $I_F=10\text{mA}$	$V_F$	0.9	V
Power Dissipation (Note 1)	$P_D$	150	mW
Thermal Resistance from Junction to Ambient	$R_{\theta JA}$	833	$^{\circ}\text{C}/\text{W}$
Junction Temperature	$T_J$	150	$^{\circ}\text{C}$
Storage Temperature	$T_{STG}$	-55~+150	$^{\circ}\text{C}$

### ELECTRICAL CHARACTERISTICS

T<sub>a</sub>=25°C unless otherwise specified

Type Number	Type Code	Zener Voltage Range (Note 2)				Maximum Zener Impedance (Note 3)			Maximum Reverse Current		Typical Temperature Coefficient @I <sub>ZT</sub> =5 mA mV/°C	
		V <sub>Z</sub> @I <sub>ZT</sub>			I <sub>ZT</sub>	Z <sub>ZT</sub> @I <sub>ZT</sub>	Z <sub>ZK</sub> @I <sub>ZK</sub>	I <sub>ZK</sub>	I <sub>R</sub>	V <sub>R</sub>	Min	Max
		Nom(V)	Min(V)	Max(V)	mA	Ω		mA	μA	V		
BZX584B2V4	2V1	2.4	2.35	2.45	5	100	600	1.0	50	1.0	-3.5	0
BZX584B2V7	2V2	2.7	2.65	2.75	5	100	600	1.0	20	1.0	-3.5	0
BZX584B3V0	2V3	3	2.94	3.06	5	95	600	1.0	10	1.0	-3.5	0
BZX584B3V3	2V4	3.3	3.23	3.37	5	95	600	1.0	5	1.0	-3.5	0
BZX584B3V6	2V5	3.6	3.53	3.67	5	90	600	1.0	5	1.0	-3.5	0
BZX584B3V9	2V6	3.9	3.82	3.98	5	90	600	1.0	3	1.0	-3.5	0
BZX584B4V3	2V7	4.3	4.21	4.39	5	90	600	1.0	3	1.0	-3.5	0
BZX584B4V7	2Z1	4.7	4.61	4.79	5	80	500	1.0	3	2.0	-3.5	0.2
BZX584B5V1	2Z2	5.1	5.00	5.20	5	60	480	1.0	2	2.0	-2.7	1.2
BZX584B5V6	2Z3	5.6	5.49	5.71	5	40	400	1.0	1	2.0	-2.0	2.5
BZX584B6V2	2Z4	6.2	6.08	6.32	5	10	150	1.0	3	4.0	0.4	3.7
BZX584B6V8	2Z5	6.8	6.66	6.94	5	15	80	1.0	2	4.0	1.2	4.5
BZX584B7V5	2Z6	7.5	7.35	7.65	5	15	80	1.0	1	5.0	2.5	5.3
BZX584B8V2	2Z7	8.2	8.04	8.36	5	15	80	1.0	0.7	5.0	3.2	6.2
BZX584B9V1	2Z8	9.1	8.92	9.28	5	15	100	1.0	0.5	6.0	3.8	7.0
BZX584B10	2Z9	10	9.80	10.20	5	20	150	1.0	0.2	7.0	4.5	8.0
BZX584B11	2Y1	11	10.78	11.22	5	20	150	1.0	0.1	8.0	5.4	9.0
BZX584B12	2Y2	12	11.76	12.24	5	25	150	1.0	0.1	8.0	6.0	10.0
BZX584B13	2Y3	13	12.74	13.26	5	30	170	1.0	0.1	8.0	7.0	11.0
BZX584B15	2Y4	15	14.70	15.30	5	30	200	1.0	0.1	10.5	9.2	13.0
BZX584B16	2Y5	16	15.68	16.32	5	40	200	1.0	0.1	11.2	10.4	14.0
BZX584B18	2Y6	18	17.64	18.36	5	45	225	1.0	0.1	12.6	12.4	16.0
BZX584B20	2Y7	20	19.60	20.40	5	55	225	1.0	0.1	14.0	14.4	18.0
BZX584B22	2Y8	22	21.56	22.44	5	55	250	1.0	0.1	15.4	16.4	20.0
BZX584B24	2Y9	24	23.52	24.48	5	70	250	1.0	0.1	16.8	18.4	22.0
BZX584B27	2X1	27	26.46	27.54	2	80	300	0.5	0.1	18.9	21.4	25.3
BZX584B30	2X2	30	29.40	30.60	2	80	300	0.5	0.1	21.0	24.4	29.4
BZX584B33	2X3	33	32.34	33.66	2	80	325	0.5	0.1	23.1	27.4	33.4
BZX584B36	2X4	36	35.28	36.72	2	90	350	0.5	0.1	25.2	30.4	37.4
BZX584B39	2X5	39	38.22	39.78	2	130	350	0.5	0.1	27.3	33.4	41.2

Notes:

- Valid provided that device terminals are kept at ambient temperature.
- Tested with pulses, period=5ms,pulse width =300μs.
- f=1kHz

### Typical Characteristics

Notes: Our company currently provide 5.1 V - 20 V products only

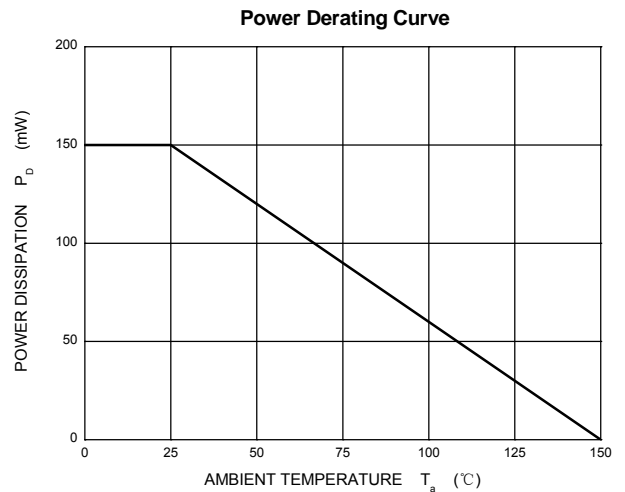
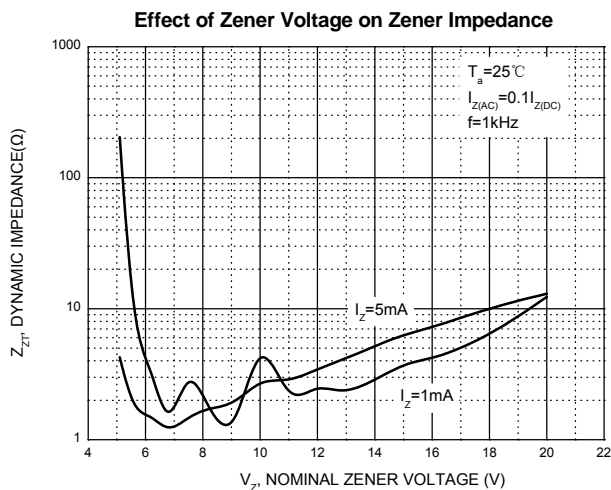
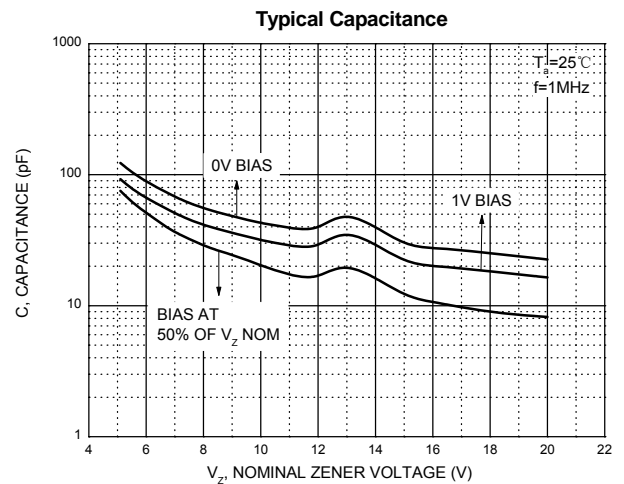
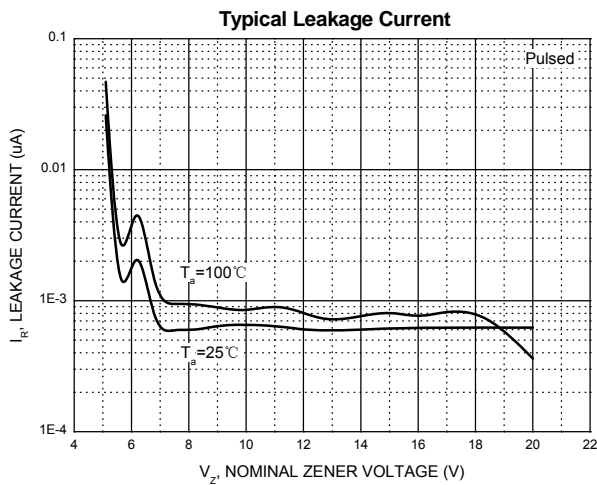
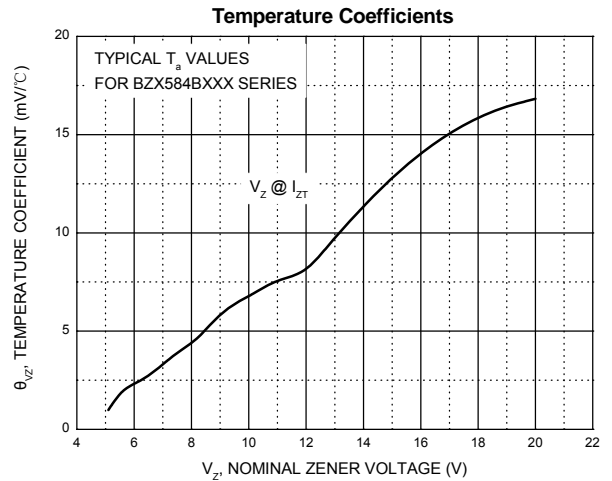
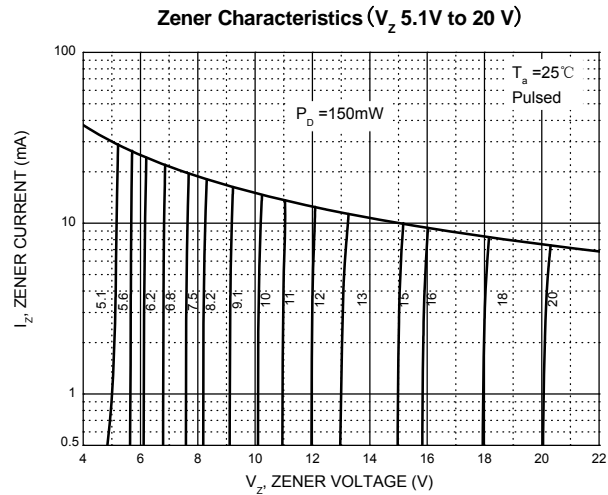

### SOD-523 Embossed Carrier Tape

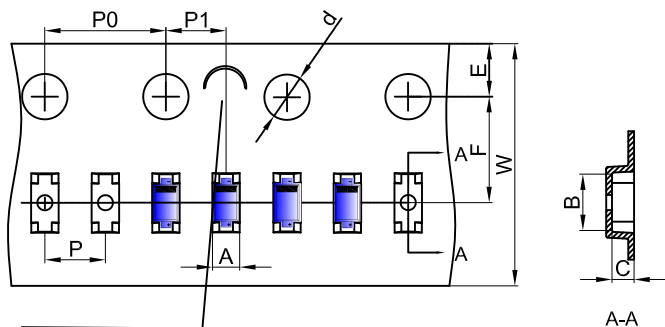

NOTE: TO GAVE 'C' ON CARRIER TAPE PER 120MM

Dimensions are in millimeter										
Pkg type	A	B	C	d	E	F	P0	P	P1	W
SOD-523	0.9	1.94	0.73	Ø1.50	1.75	3.50	4.00	2.00	2.00	8.00

### SOD-523 Tape Leader and Trailer

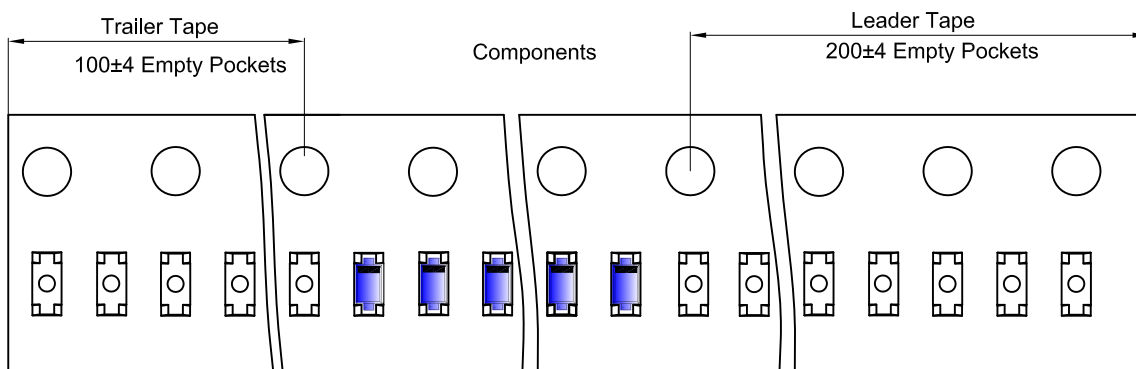

### SOD-523 Reel

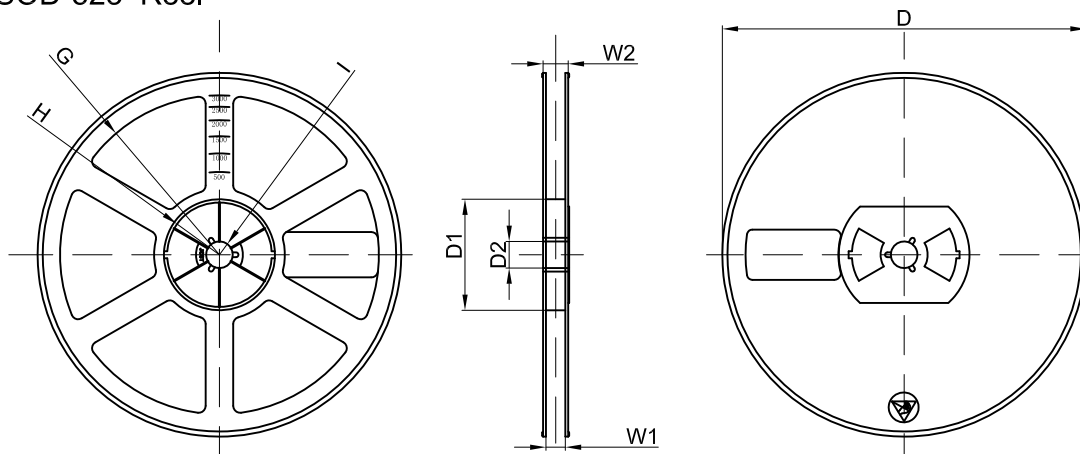

Dimensions are in millimeter								
Reel Option	D	D1	D2	G	H	I	W1	W2
7" Dia	Ø178.00	54.40	13.00	R78.00	R25.60	R6.50	9.50	12.30

REEL	Reel Size	Box	Box Size(mm)	Carton	Carton Size(mm)	G.W.(kg)
8000 pcs	7 inch	120,000 pcs	203×203×195	480,000 pcs	438×438×220	

### SOD-523 Package Outline Dimensions

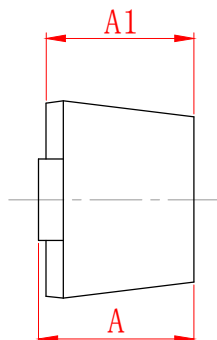
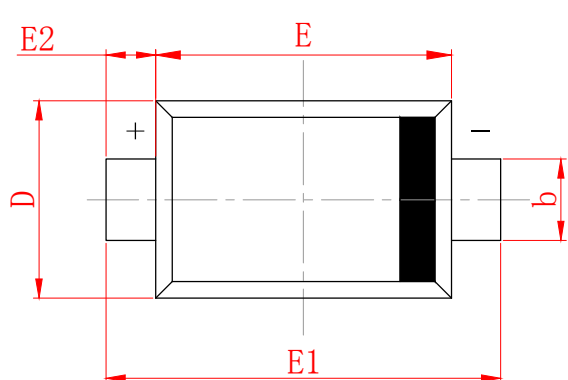

SYMBOL	MILLIMETER	
	MIN	MAX
A	0.530	0.730
A1	0.500	0.700
b	0.280	0.380
c	0.080	0.150
D	0.750	0.850
E	1.100	1.300
E1	1.500	1.700
E2	0.200 REF	
L	0.010	0.070
$\theta$	7° REF	

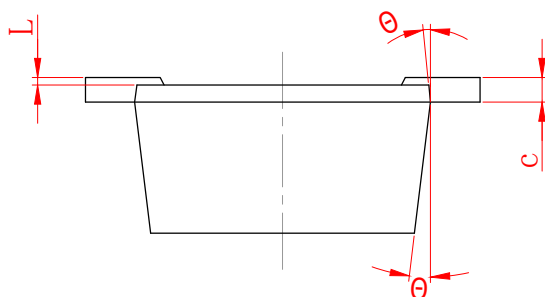

### DISCLAIMER

JHG PROVIDES TECHNICAL AND RELIABILITY DATA (INCLUDING DATASHEETS), DESIGN RESOURCES (INCLUDING REFERENCE DESIGNS), APPLICATION OR OTHER DESIGN ADVICE, SAFETY INFORMATION, AND OTHER RESOURCES "AS IS" AND WITH ALL FAULTS, AND DISCLAIMS ALL WARRANTIES, EXPRESS AND IMPLIED, INCLUDING WITHOUT LIMITATION ANY IMPLIED WARRANTIES OF MERCHANTABILITY, FITNESS FOR A PARTICULAR PURPOSE OR NON-INFRINGEMENT OF THIRD PARTY INTELLECTUAL PROPERTY RIGHTS.

These resources are intended for skilled developers designing with JHG products. You are solely responsible for

- (1) selecting the appropriate JHG products for your application;
- (2) designing, validating and testing your application;
- (3) ensuring your application meets applicable standards, and any other safety, security, or other requirements.

These resources are subject to change without notice. JHG grants you permission to use these resources only for development of an application that uses the JHG products described in the resource. Other reproduction and display of these resources are prohibited. No license is granted to any other JHG intellectual property right or to any third party intellectual property right. JHG disclaims responsibility for, and you will fully indemnify JHG and its representatives against, any claims, damages, costs, losses, and liabilities arising out of your use of these resources.